

Loan
Sea Grant Depository

LOAN COPY ONLY

DEVELOPMENT OF A CENTRAL STAY
COLLISION TOLERANT PILE STRUCTURE

A technical memorandum submitted to the

U. S. Coast Guard
2100 2nd. St. S. W.
Washington, D. C. 02593

and the

U. S. Coast Guard R&D Center
Avery Point
Groton, CT 06340

by

M. Robinson Swift
Associate Professor
Mechanical Engineering

Andrew Dudka
Undergraduate (Senior)
Mechanical Engineering

Richard Villeneuve
Undergraduate (Senior)
Mechanical Engineering

James Ward
Graduate (M.S.)
Ocean Engineering

Kenneth Baldwin
Assistant Professor
Mechanical Engineering

University of New Hampshire
Durham, NH 03824

December 18, 1986

1. INTRODUCTION

Background

The hinge component is the crucial element of a Collision Tolerant Pile System (CTPS) design. After careful consideration of many different concepts, Swift and Baldwin (1985) identified two systems which appeared to have the potential for meeting hinge design requirements - the peripheral stay/central universal joint configuration and the central stay system. The peripheral stay concept received initial emphasis in the UNH program and its development has been reported by Swift and Baldwin (1985,1986), Cloutier et al. (1985), Durkee (1986) and Mielke (1986). Recently, more attention has been devoted to the central stay arrangement as a design alternative.

The central stay configuration is shown schematically in Fig. 1. Major components are the base, the bell, the central stay attached to a pre-stressed spring, and the (hollow) pile. As the pile tips, it pivots about the bell/base contact point, while the stay force provides the restoring moment. The system is very simple and workable mechanically. Because the method of attachment is flexible, however, there were initial concerns about attachment security and the possibility of jamming.

Previous Development Work

The central stay concept was considered briefly by the senior design team which eventually built the peripheral stay, 1/4 scale (approximately 12 ft. tall) physical model described by Cloutier et al. (1985). A smaller cardboard and wood presentation model of a central stay system, however, was fabricated during their investigation. Though crude in construction, the model did clearly demonstrate that the concept had potential.

Consequently during the following (1985-86) academic year, another senior design team designed and built a 1/15 scale (approximately 2 1/2 ft. tall) central stay physical model for testing. During the design phase, the geometry of the base parts' interfacing was analyzed. The objective was to shape the parts to minimize the possibility of jamming and also to maintain stay moment arm with respect to the contact point. When a configuration having these characteristics was found, the system physical model was fabricated.

Testing consisted, first of all, of measuring hinge moment as a function of inclination angle in a "bench test". The righting moment was found to be strong throughout the angle range and always exceeded the upsetting moment due to gravity. Free return to the vertical was prompt, and unlike the peripheral stay models, recovery was not hindered by friction.

Next the model was collision tested in water using a scale model barge. The pile was set up in approximately 2 ft. (30 ft. full scale) of water and hit by the barge towed over the pile location. Speeds ranged up to 3 knots (over 10 knots full scale) and barge draft was varied from .2 ft. to .8 ft. (3 ft. to 12 ft. full scale). In all cases, no damage was incurred, no tendency to jam was observed, and

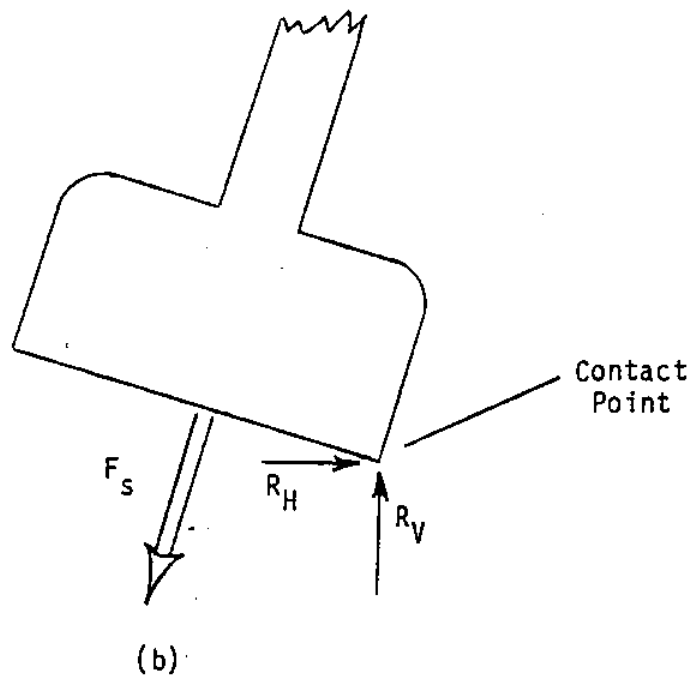
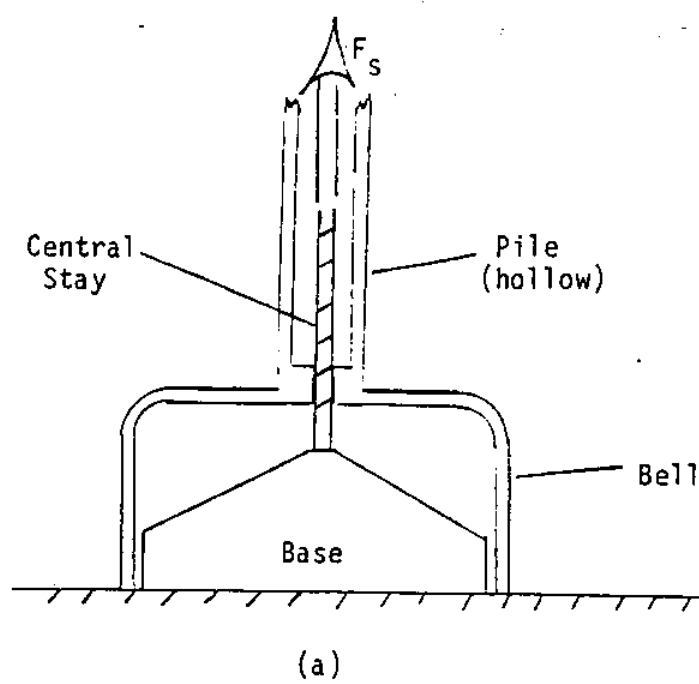

Fig. 1. Schematic drawings of the central stay hinge. Fig. (a) shows a cross-section of the hinge which is circular in plan view. F_s is the force due to a pre-stressed, internal spring. Fig. (b) is a partial free body diagram of the tipped hinge in which the hinge forces are shown. A restoring moment is generated by F_s acting about the contact point. R_H , R_V are contact point reaction force components.

recovery was prompt.

Present Investigation

The success of the 1/15 scale, central stay physical model prompted an effort to bring the level of development of this hinge concept up to that of the peripheral stay configuration. Specifically, a new senior design project was begun in the Fall 1986 semester to design, build and test a 1/4 scale, central stay physical model. This latest investigation, described in this report, made rapid progress due to the design experience and test procedures/equipment developed in previous work.

Using an understanding of optimum shaping of the hinge parts gained from the 1/15 scale model study, the hinge bell and base were designed for proper relationship between cable lead and the contact point. The hinge component was then made and installed on the pile/spring system used in the 1/4 scale peripheral stay studies. The design and construction details are presented in Section II. The completed system was subject to bench testing in which the hinge moment was measured as a function of inclination angle. Results showing the hinge stiffness characteristics are provided in Section III. Collision experiments were carried out off Adam's Point, NH using the same barge and pile foundation employed in the Cloutier et al. (1985) and Mielke (1986) studies. Observations from these tests are discussed in Section IV.

II. DESIGN

Drawings of the 1/4 scale, central stay design are presented in Fig. 2, while photographs of the hinge itself are shown in Fig. 3. A list of dynamic parameter values is included in Table 1.

As seen in the figures, the design base provides resistance against sliding of the contact point and an attachment position for the end of the cable. The attachment position is high enough to prevent excessive moment arm loss at large angles. Yet the position is low enough for the cable force to always be pulling down towards the contact point. The top of the base is cone-shaped so that the bell is always guided back to the proper placement during recovery.

Because the physical model was to be used for short-term testing of the concept only, no attempt was made to use long-life materials. Since the base was fixed to the foundation, its weight was also not important, and it was fabricated simply of a steel skeleton with a concrete filler. The bell and sleeve insert, on the other hand, were made without unnecessary weight yet built to have sufficient strength to transmit the hinge bending moment to the pile.

The cable (1/4 inch wire rope) leads from the base attachment position up through a central guide at the bottom of the pile and is attached inside the pile to the spring. The spring is the same one made by Mielke (1986) for his peripheral stay design experiments and consists of 70, 3/8 inch, rubber strands. The spring was pre-stressed to a force of 560 lbs. (36,000 lbs. full scale) by tightening the upper cable. The pile itself is a 5 inch aluminum pipe and is capped at the top with a clamping mechanism for securing the upper cable.

Full scale equivalents for selected dimensions, weights and other parameter values are given in parentheses. Here the term "full scale" refers to a design appropriate for a water depth of 30 ft. Numerical values were scaled up using geometrical and Froude scaling and assuming a model to prototype scale ratio of 1/4. Thus full scale velocities/model velocities = 2, full scale time intervals/model time intervals = 2, full scale linear dimensions/model linear dimensions = 4, full scale areas/model areas = 16, and full scale forces/model forces = 64. The full scale numbers should be interpreted as being advisory only since modifications to reduce extreme values will undoubtedly take place in the prototype design.

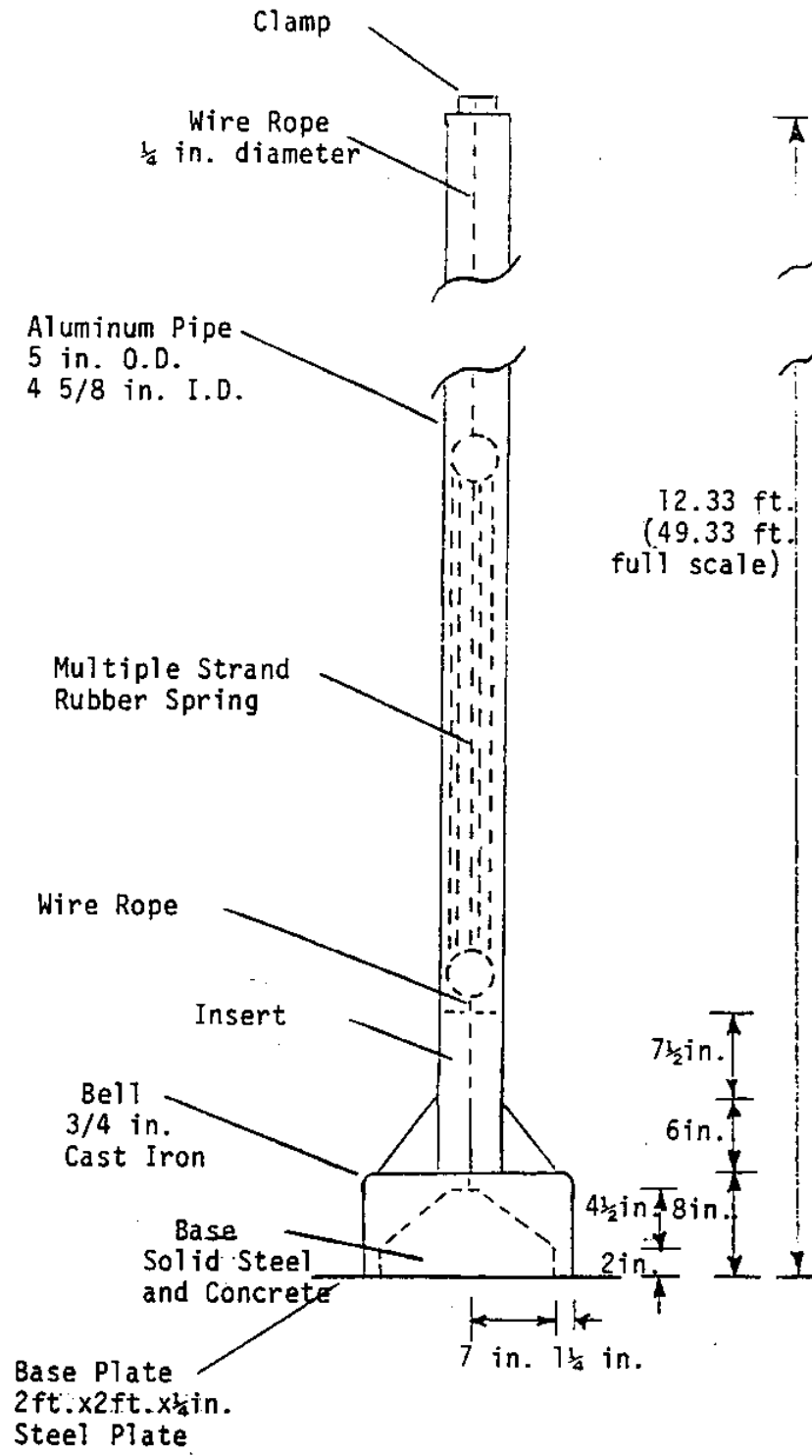
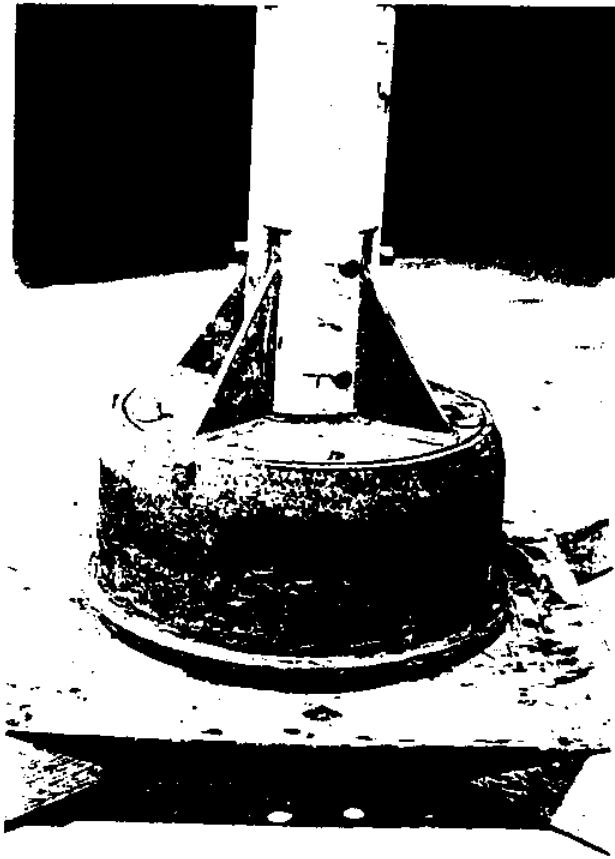

Fig. 2. The 1/4 scale, central stay physical model. The bell top is joined to a pipe insert and reinforced with 4 gussets. The pipe (with slots cut for the gussets) slips over the insert for easy assembly/disassembly. The spring is pre-stressed by winching the upper cable, tightening the clamp and removing the winch.



(a)



(b)

Fig. 3. The $\frac{1}{2}$ scale, central stay hinge. Photo (a) shows the system in the upright position, while in (b) the pile is tipped.

Table 1. Design dynamic parameters.

<u>Parameter</u>	<u>Value</u>
Mass	4.97 slugs
Weight	160 lbs. (10,240 full scale)
Height of center of mass with respect to base plate (= d_g)	2.56 ft.
Mass moment of inertia with respect to center of mass	33.0 slug - ft. ²
Mass moment of inertia about contact point when tipped	60.6 slug - ft. ²

III. BENCH TEST

The first testing to evaluate hinge performance consisted of measuring the restoring moment as a function of inclination angle in an out of water "bench test". The pile base was fixed to the laboratory floor as indicated in the Fig. 4 schematic. A tipping force was applied near the top of the pile as shown, and the perpendicular force component, moment arm with respect to the base contact point and the inclination angle were recorded. The applied moment M_a was then calculated according to

$$M_a = F_a d_a \quad (1)$$

where F_a and d_a are the perpendicular force and distance, respectively, shown on Fig. 4. The hinge, however, also supports the moment load due to gravity. Thus the hinge moment is defined as

$$M_H = M_a + W d_g \quad (2)$$

where W is the pile weight and d_g is the weight perpendicular distance as denoted in Fig. 4.

Results for hinge moment as a function of inclination angle θ are given in Fig. 5. For reference, the gravitational moment is also given. It is seen that the system has more than sufficient righting moment to generate a prompt recovery at all angles.

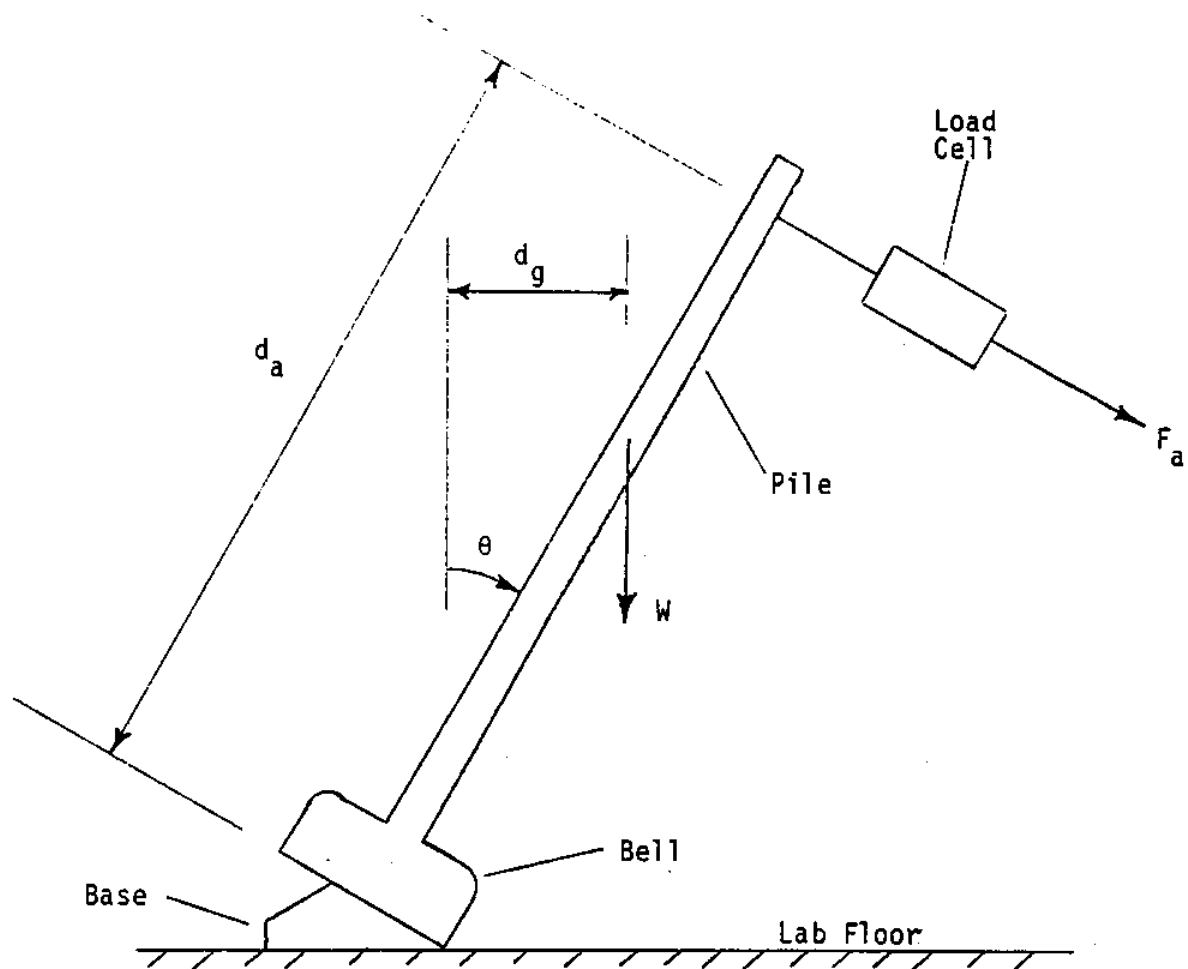

Fig. 4. Bench test schematic and nomenclature.

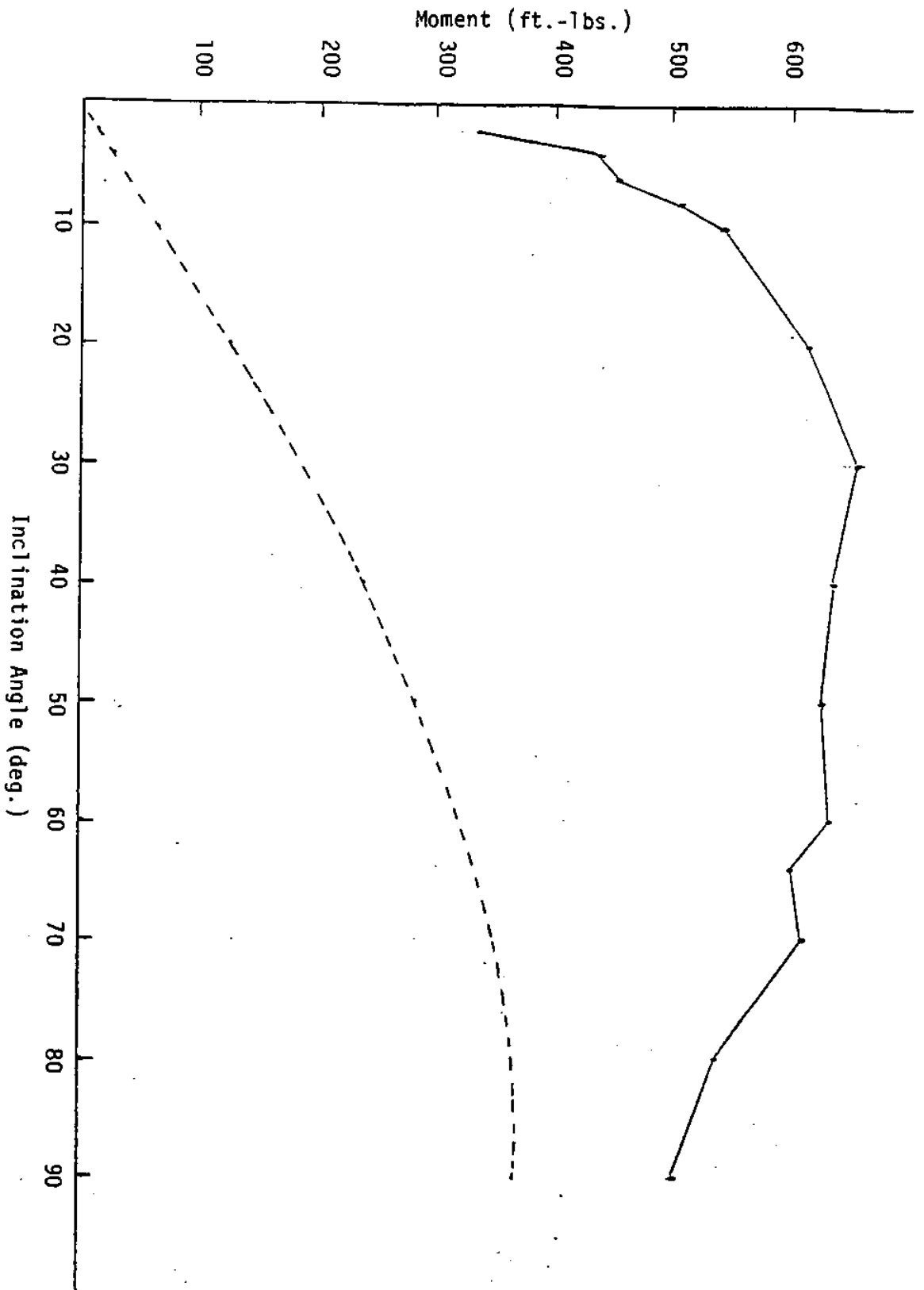

Fig. 5. Moment as a function of inclination angle. Plotted are hinge moment, M_h , as (—) and weight moment, M_d as (---). Maximum hinge moment is 648 ft.-lbs. (41,5000 ft.-lbs. full scale).

IV. COLLISION TEST

In water collision tests were conducted to determine the system's response to impact and how well it would recover dynamically from knockdowns. The hinge consists of rigid pivot parts and a flexible cable attachment, and hinge kinematic and dynamic performance could change with force levels. Since force levels in this 1/4 scale experiment would be approximately 50 times greater than in the previous 1/15 scale tests, we would be able to tell if the concept had any inherent problems not uncovered in the smaller scale experiments.

One area of particular concern was that local damage would occur at the base/bell contact point. Another possibility would be that barge impact low on the pile would knock the bell off the base, stretching the cable/spring system, and that the hinge would recouple in a jamming mode rather than be guided into proper alignment. It should be emphasized that these scenarios had not been observed in previous physical model studies, but through conjecture, had been described as objections to the concept. Thus a primary purpose of the collision experiments was to resolve these issues.

The CTPS was deployed off Adam's Point on the foundation installed by Cloutier et al. (1985). Water depth at the site is normally 1 ft. at low tide and 8 ft. at high water with variations due to the spring-neap cycle. Mounting, maintenance and removal were therefore easily done at low water, while collision experiments were done at the scaled design depth at high tide. The 13 ft. barge built by the Cloutier student team was towed so as to impact the pile. The barge was partially filled with water to add sufficient mass such that barge speed was not altered by collision. Due to wind and current factors making the towed barge difficult to control, the highest impact speed was limited to just over 3 knots (6 knots full scale). An observation record was kept by video and still photography.

A summary of collision tests made on October 24, 1986 is contained in Table 2, and a composite photo sequence is shown in Fig. 6. Though high speeds could not be achieved by the barge, the pile collision response was entirely satisfactory. No local damage was incurred at either the point of barge impact or at hinge contact points. There were no kinematic problems or tendency to jam. Even when the pile was snagged by the towline and pulled axially, recovery was smooth and as designed. Recovery in general was prompt - less than 0.5 sec. (1 sec. full scale) - and due to the absence of friction, appeared considerably more certain than the peripheral stay system.

Table 2. Summary of October 24, 1986 collision testing. All runs were made in a northerly direction against a wind ranging in speed from 12 - 18 knots and against a tidal current of approximately 1/2 knot. Water depth over the base plate was about 6 ft. Recovery in all cases was prompt. Time of release to full upright position was always less than 0.5 sec.

Barge Parameters

<u>Length</u>	<u>Freeboard</u>	<u>Bow Rake Angle</u>	<u>Draft at Bow Rake Extension</u>	<u>Draft at Stern</u>
13 ft.	1.33 ft.	25 deg.	3 ft. (12 ft. f.s.)	1 ft. (3 ft. f.s.)

Experiment Descriptions

<u>Run</u>	<u>Type of Hit</u>
1.	Pile snagged by starboard tow rope, pulled down slightly and released off starboard side of barge.
2.	Tow lines crossed bringing down pile before a direct hit by the lower bow rake.
3.	Direct hit.
4.	Snagged by starboard tow rope, guided on to barge bow, hit by bottom of bow rake before slipping out starboard side for recovery.
5.	(Same as 1.)
6.	Direct hit.
7.	Direct hit. The barge was assisted by an outboard skiff acting as a tug. This was the highest speed run with the barge traveling over 3 knots (6 knots full scale).
8.	Snagged by port towline which caught at the pile tip and exerted an axial pulling load directly from the towing vessel.

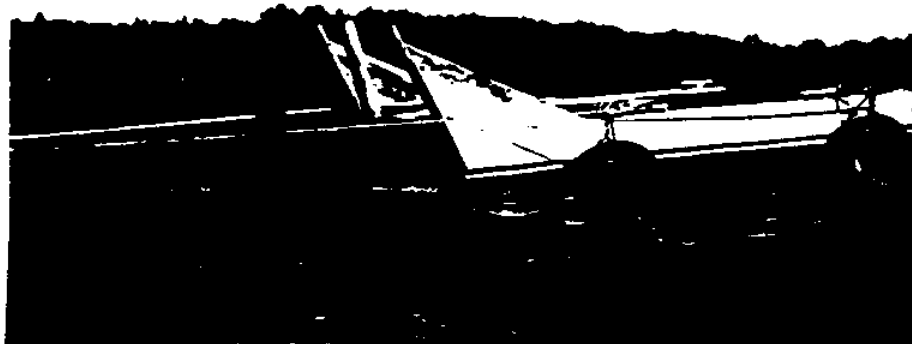

(a)

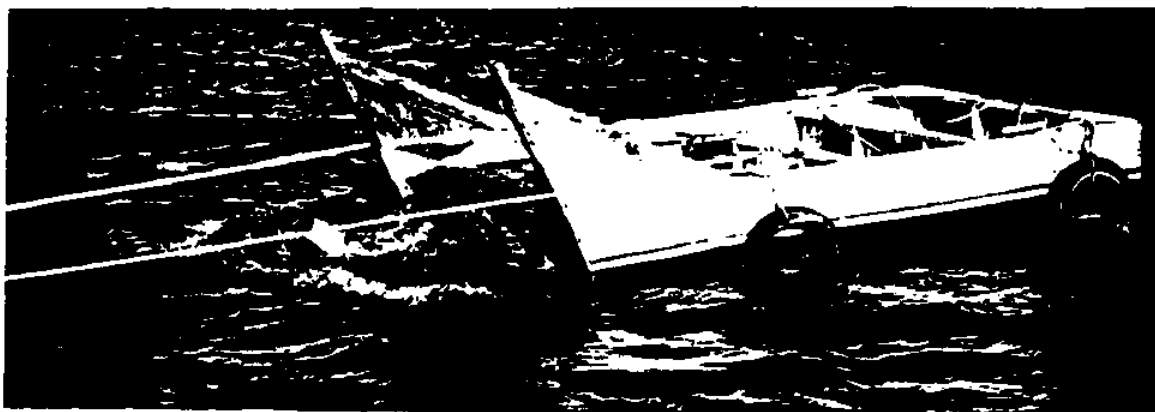

(b)



(c)

Fig. 6. Collision testing off Adam's Pt., NH on Oct. 24, 1986. In (a) contact has just been made with the upper bow rake; (b) shows the pile being pushed down by the lower bow rake, while (c) show the pile recovery.

V. CONCLUSION

Results were successful and encouraging. Though more high speed collision testing would be desirable, it is clear that the central stay concept is a simple, viable design alternative to the peripheral stay configuration.

VI. REFERENCES

- Cloutier, R., T. Bier, C. Byrne, T. Sears and C. Tuttle (1985) "The Design, Development and Testing of a Quarter Scale Collision Tolerant Pile Structure", a final report for the 84-85 Sea Grant Sponsored Ocean Projects Course.
- Durkee, R. A., (1986) "A Mathematical Model for the Three-Dimensional Dynamics of a Collision Tolerant Pile Structure", M. S. Thesis submitted to the Mechanical Engineering Dept., UNH, Durham, NH.
- Mielke, D. (1986) "Development and Testing of a Collision Tolerant Pile Structure", (in preparation).
- Swift, M. R. and K. C. Baldwin (1986) "The Development of a Collision Tolerant Pile System Concept", Ocean Engineering, Vol. 13, No. 2, pp. 131 - 156.
- Swift, M. R. and K. C. Baldwin (1985) "The Design and Model Testing of a Collision Tolerant Pile Structure", Final Report submitted to the U. S. Coast Guard R&D Center, Avery Point, Groton, CT.

National Sea Grant Depository
Pell Library Building - GSO
University of Rhode Island
Narragansett, RI 02882-1197USA
