



REDUCTION OF COASTAL STORM DAMAGES TO RESIDENTIAL STRUCTURES:
MODIFYING EXISTING UNELEVATED STRUCTURES

CIRCULATING COPY
Sea Grant Depository

William R. Gordon, Jr.

LOAN COPY ONLY

Introduction

Many New England homes located in coastal flood hazard zones were built before the 1968 National Flood Insurance Program required that the first floor of occupancy be located above the 100 year flood plain (the peak flood level of a storm having the chances of occurring once every 100 years). Such construction also took place before the creation and implementation of local municipal and state zoning (zoning created to enforce the Flood Insurance standards).

Present law does not require that these existing unelevated structures be raised to elevations required of new construction. In many instances, the cost of doing so would be a prohibitive factor. But homeowners can follow the procedures outlined here to reduce flood damage from future storms.

It should be understood that:

- 1) Elevating the house would offer better protection.
- 2) These procedures cannot prevent flood damage but can reduce it in minor or moderate storms.
- 3) These procedures are most effective in areas of stillwater flooding, such as the landward side of a barrier beach or on mainland areas adjacent to a barrier pond or bay.
- 4) Homeowners should consult a certified engineer or architect before following these procedures to determine stress limits in the design and construction of restraints for the house.

Primary Concern

In major flooding, an unelevated, unsecured house is very likely to float off its foundation because of hydrostatic uplift (floating power of water). In past hurricanes a tremendous loss of property resulted from houses colliding

with one another. Similar damages have occurred as a result of severe winter storms, such as the Blizzard of 1978. Two ways to keep a house onsite are: 1) to secure it with restraints, and 2) to reduce the hydrostatic pressure of rising waters.

Securing the Structure - Use of Cement Anchors

To prevent the house from floating offsite it is necessary to connect it to a series of cement or concrete anchors. The cement anchors are reinforced with steel rod to prevent the cable fastener from pulling free. The number of anchors and their location vary, as shown in Diagram 1. Poured cement weighs approximately 145 pounds per cubic foot. A four cubic foot block weighs nearly 5 tons, thus providing substantial weight in a conveniently small volume.

Because wood is not as dense as sea water, an anchor is needed not only to offset the hydrostatic uplift of the house, but also to offset the additional stress put on the structure by hurricane force winds. It is essential that an engineer or architect determine the stress loads of a house and recommend the number and size of anchors to be used.

Diagram 1

Anchors shown in Diagram 1 are for use in cases where the structure is already supported. The anchor in Diagram 2 also serves as a support for the structure if replacement of existing piers, blocks or pilings is required. For aesthetic reasons, in placing the anchor, cement should be poured below ground level. The anchor should be as close to the structure as excavating and pouring of the form permit. This will also reduce the length of exposed cable. Anchors may be placed at opposite corners or may be placed at the midpoint of the opposite side of the house.

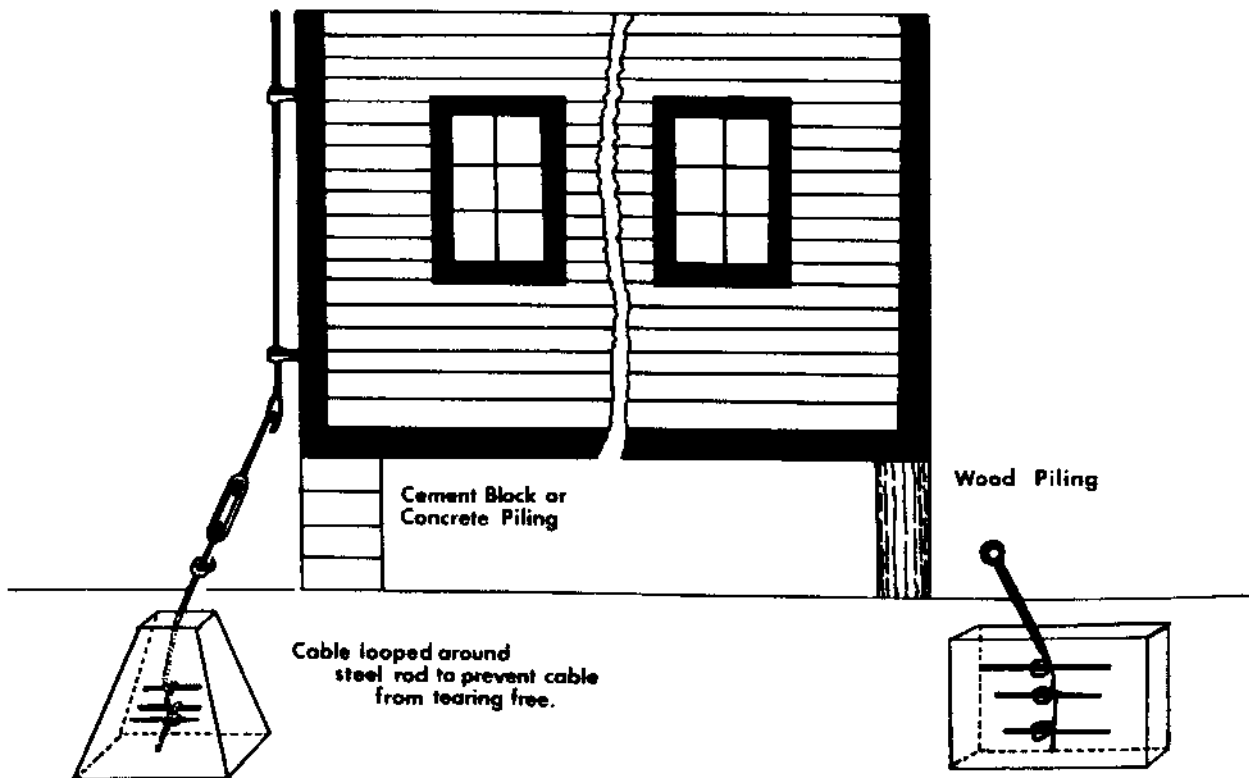
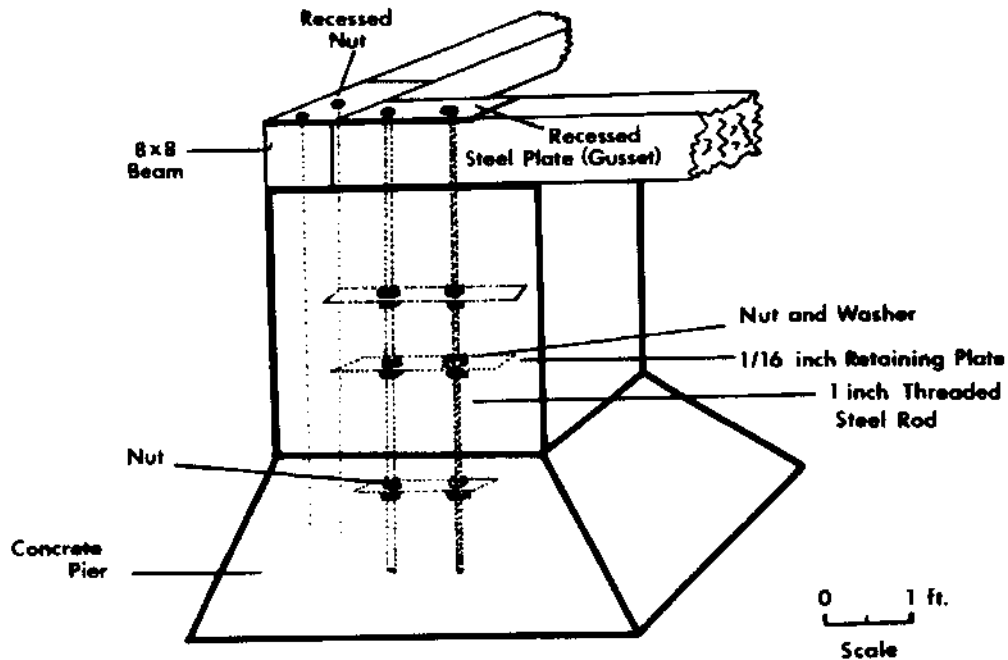

Diagram 2

Combined anchor and support. Existing support piers frequently 'kick out' from beneath a house during flooding. This is a result of hydrostatic uplift, along with lateral stress created by the impact of water and wind on the side of the house. Cement block piers, if not reinforced, will fall away as the structure floats. Wood pilings will pull out of the subsoil if they are not placed at an adequate depth. Consult an engineer or architect to determine whether your house's supports should be replaced. Proper cable restraint will offset uplift and toppling.



All Steel must be Galvanized.

Diagram 3

In many instances a house will shear away from its supports during flooding. Diagram 3 illustrates possible methods to adequately fasten the structure to wood pilings.

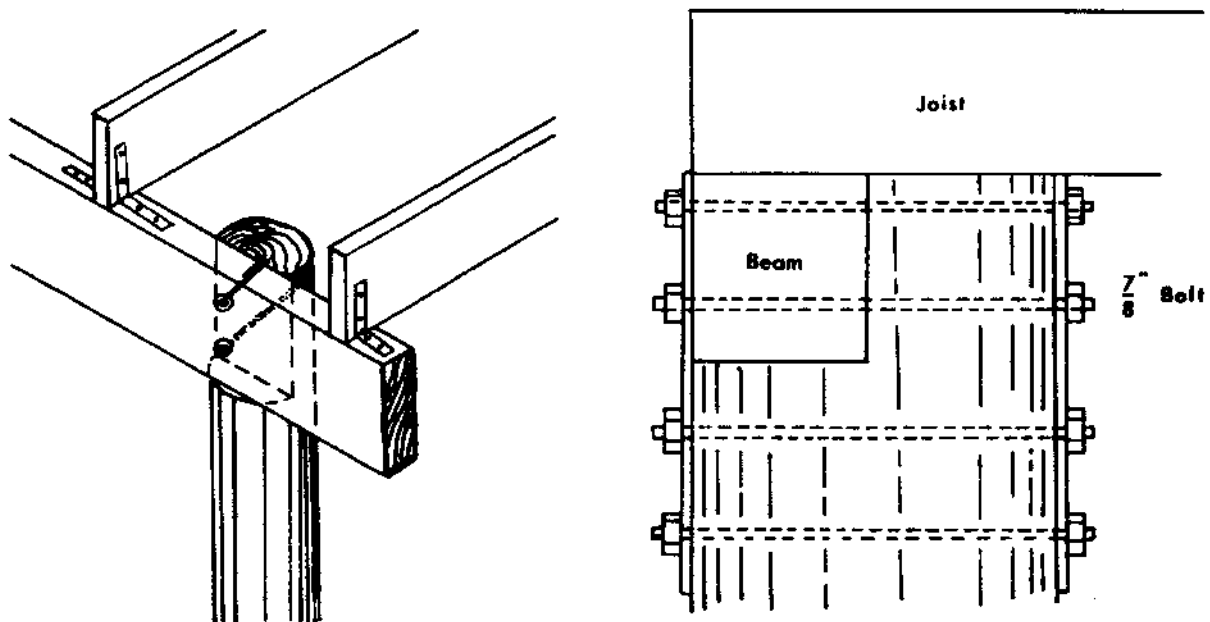

Securing the Structure - Use of Cabling

Steel cable is used to secure the house to its anchors. A single length of cable can be run from an anchor up along the outside wall (connected to 'cyclone' or eye bolts) to the eave plate and truss rafters, drawn over the joists of the rafters to the opposite wall, then outside and down to a second anchor. (Diagram 4)

Diagram 4

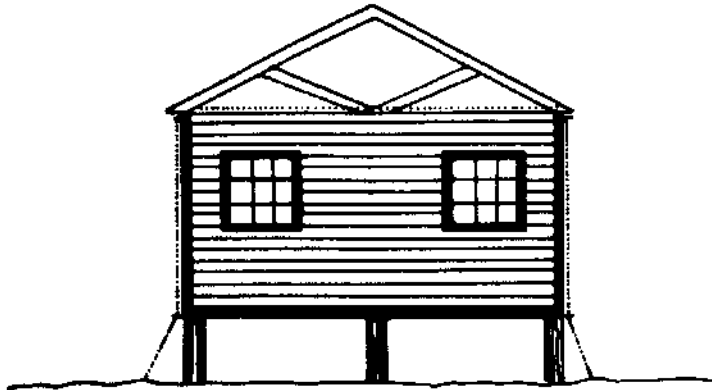

This method is suggested because many existing homes are not adequately designed and built for hurricane force winds. If the cable were secured only to the floor joists of the first floor, the house might shear from the force of the wind. Running the cable up and through the house exerts a stabilizing pressure around it. Securing the truss rafters adds to their strength and helps to hold the roof down. Winds from a hurricane create opposite forces on the roof of a house. The wind will press on one side of the roof while trying to lift the other side.

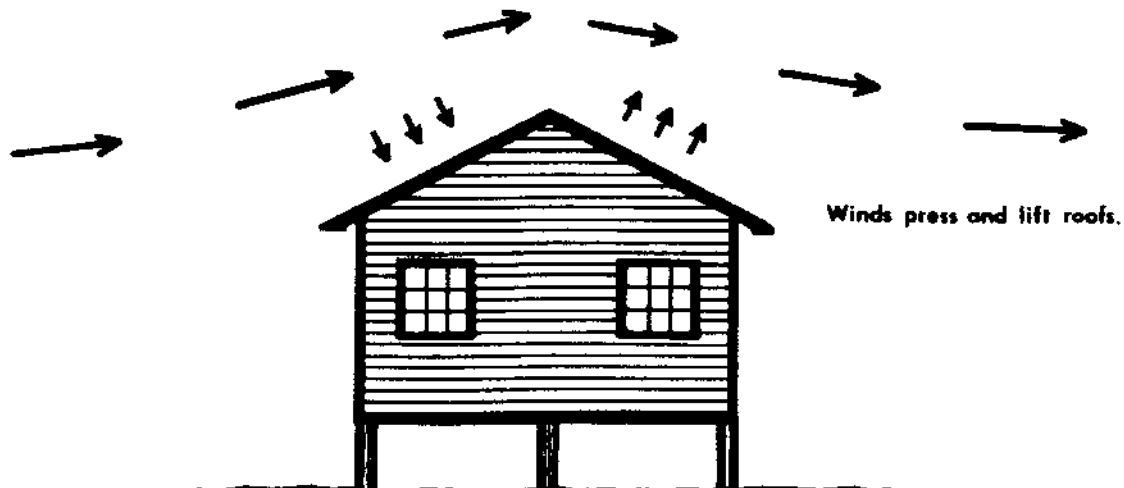

Improper fastening of the roof will create structural weakness that cannot be corrected by cabling. Diagram 5 illustrates the use of metal tie-downs to secure the roof frame to the walls. The metal tie-downs should be used with each truss rafter.

Diagram 5

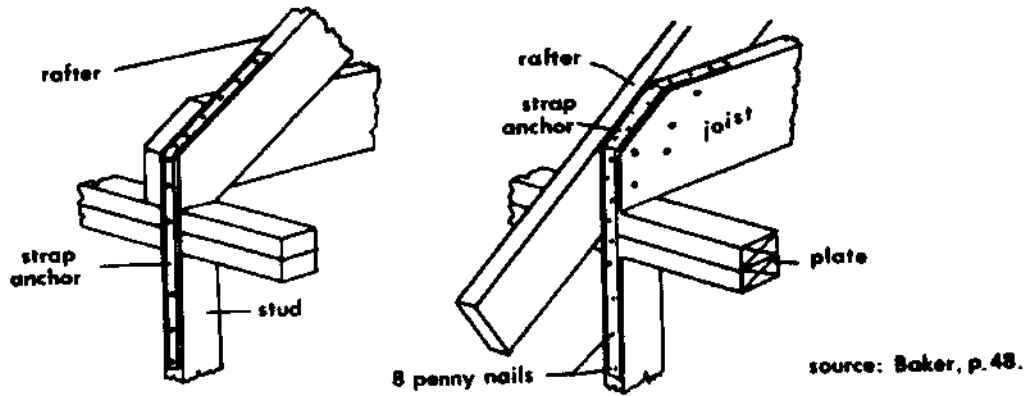

A single cable with two anchors may secure the structure. Crisscrossing two cables to opposite corners or walls offers even greater strength. Cables may be secured to the rafter joists with brackets to prevent slippage. (Diagram 6)

Diagram 6

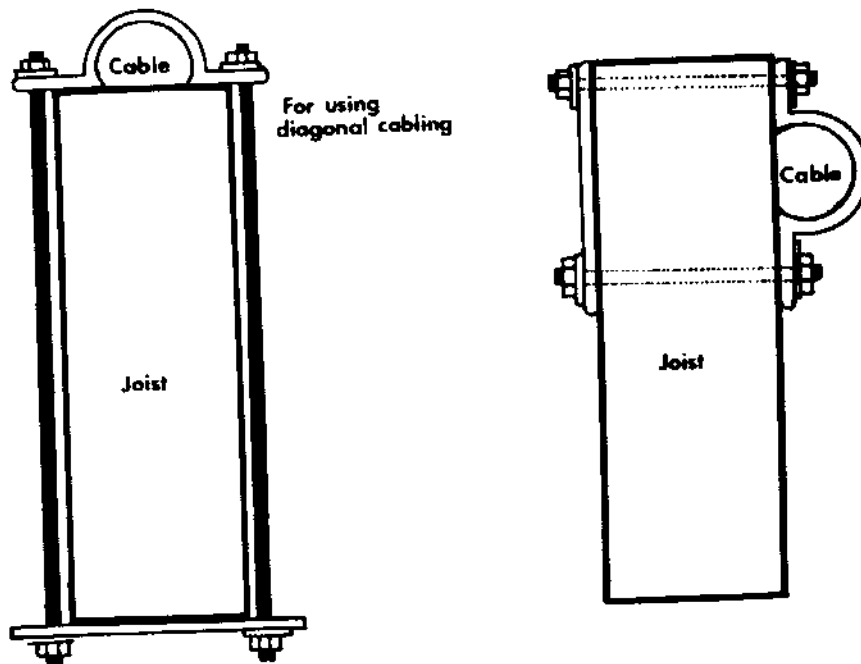

Reducing Hydrostatic Pressure with Trap Doors

Unless a structure is sufficiently elevated, water is bound to enter during flooding. As mentioned, a house will float off its supports partly because of the difference in density between its wood construction and sea water, and partly because of dead air spaces under the first floor and between the floor joists. Rising water traps this air beneath the house and adds to the buoyancy of the structure.

Trap doors on the first floor can relieve hydrostatic pressure created by trapped air. A one-foot-square door or panel should be installed in every ground floor room. This can be a piece of flooring cut so that when installed or replaced it will rest securely upon the floor joists. (Diagram 7) The trap door may be a metal covering similar to a chimney flue plate or an electrical box door, placed over a hole in the floor. In either case, the trap door should be adequately fastened to the joists or flooring to prevent tripping. A scatter rug or a piece of furniture may be used to hide its presence.

When a severe winter storm or hurricane threatens, unfasten the panels. As the water rises the panels will pop off, reducing the hydrostatic pressure from the dead air spaces under the floor. The rising water forces most of this dead air up through the holes. The water in the house will rise only to the still water level of the flood and, most importantly, the added weight of the water inside the house will further act to anchor it. (This is in effect the result of a loss of the density of the wood materials of the house from inundation). This water will also equalize the stress placed on the outside walls from wind and flooding. Trap doors need not be placed in homes with open space heaters located beneath the house. The grill plates in the floor will allow the water to enter.

If there is not time to remove furniture and belongings from first floor rooms, move them as high as possible -- to upper floors, the attic, on top of tall furniture.

Diagram 7

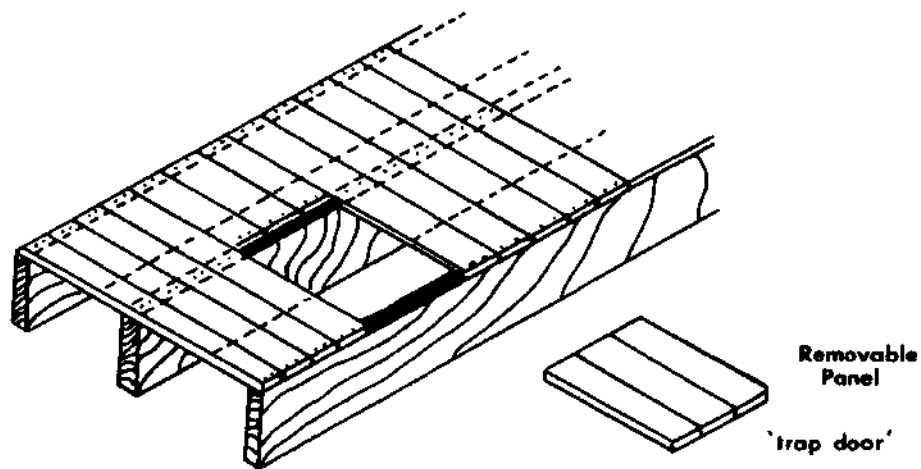

Conclusion

This brochure is aimed at reducing structural damage to a house or cottage during coastal flooding by helping to keep it onsite. Water damage to its interior is inevitable. Even if the house floats, it sits deep enough in the water for damage to occur. Consequently, it is suggested that water-damage resistant materials be used in ground floor rooms. There is considerable literature available on keeping water out of buildings, but the flood-proofing techniques cited are not feasible with wood construction.

References and Other Material

- Anderson, L.O. and Walton R. Smith. Houses Can Resist Hurricanes, U.S. Forest Service Research Paper FPL 33. U.S. Department of Agriculture, August, 1965.
- Baker, Simon. Storms, People and Property in Coastal North Carolina. Raleigh, N.C.: University of North Carolina Sea Grant Publication, UNC-SG-78-15, August 1978.
- Burton, Ian; Kates, Robert W.; and Snead, Rodman. The Human Ecology of Coastal Flood Hazard in Megalopolis. Chicago: The University of Chicago, Department of Geography Research Paper No. 115, 1969. p. 133.
- Collier, C.A. Construction Guidelines to Minimize Hurricane Damage to Shore Area Homes. Florida Department of Natural Resources, Tallahassee, 1976.
- FHA Pole House Construction. American Wood Preservers Institute, McLean, Va.
- Gordon, William R. "The Perception of Storm Hazard of Selected Rhode Island Barrier Beach Inhabitants". unpublished M.A. thesis, University of Rhode Island, 1980. p. 84.
- How to Build Storm Resistant Structures. National Forest Products Association, Washington, D.C.
- Ogg, R.D. Anchors and Anchoring. Danforth Division of the Eastern Company, Portland, Me. 1977.
- Walton, Jr., Todd L. Hurricane-Resistant Construction for Homes, SUSF-SG-76-005. Florida Sea Grant Program, Gainesville, Fl. 1976.

THE PREPARATION OF THIS PUBLICATION WAS FINANCED BY A GRANT FROM FOUR COMPONENTS OF NOAA: THE OFFICE OF COASTAL ZONE MANAGEMENT, THE ENVIRONMENTAL DATA & INFORMATION SERVICE, THE NATIONAL MARINE FISHERIES SERVICE, AND THE OFFICE OF SEA GRANT. THE CONTENTS DO NOT NECESSARILY REFLECT THE OFFICIAL VIEWS OR POLICIES OF THE SPONSORING AGENCIES. THIS PUBLICATION MAY BE REPRINTED, IN PART OR IN FULL, WITH THE CUSTOMARY CREDITING OF THE SOURCE.

ADDITIONAL COPIES OF THIS PUBLICATION ARE AVAILABLE FROM URI, MARINE ADVISORY SERVICE, PUBLICATIONS UNIT, BAY CAMPUS, NARRAGANSETT, RI 02882.

P919 6/81 500

NATIONAL SEA GRANT DEPOSITORY
PELL LIBRARY BUILDING
URI, NARRAGANSETT BAY CAMPUS
NARRAGANSETT, RI 02882

COASTAL INFORMATION
DIVISION OF MARINE RESOURCES
URI BAY CAMPUS
NARRAGANSETT RI 02882

RECEIVED
NATIONAL SEA GRANT DEPOSITORY
DATE: JUL 14 1981